

# APPLICATIONS OF HIGH-PRESSURE BALLOONS IN THE MEDICAL DEVICE INDUSTRY

Mark A. Saab, President, Advanced Polymers, Inc.

[www.advpoly.com](http://www.advpoly.com)

---

## INTRODUCTION

Recent advances in the design and fabrication of high-pressure medical balloons have enhanced their performance and expanded their use into new applications in the medical device industry. Developed in the late 1970s, high-pressure balloons have traditionally been used in angioplasty, a procedure that opens blood vessels clogged by built-up, fatty plaque. The balloon, tightly wrapped around a catheter shaft to minimize its profile, is inserted through the skin and into the narrowed section of the vessel. Inflating the balloon, typically with a radiopaque solution or saline forced through a syringe, exerts high pressure, which compresses the plaque against the wall of the vessel and allows the blood to flow normally. For retraction, a vacuum is pulled through the balloon to collapse it. The procedure was developed as a less invasive and less costly alternative to coronary bypass, a complex surgical procedure that skirts the blockage by grafting a section of vein, typically taken from the leg, to locations above and below the afflicted area.

Today high-pressure balloons, with thinner walls, higher strength, and smaller profiles, are well suited for use in a broad range of minimally invasive procedures. They can be produced in a wide range of diameters, lengths, and shapes, including complex custom shapes for specific applications and specialty coatings for added performance. Enhancements in balloon design and technology have provided increased flexibility to designers of medical devices, making the development of new and improved devices possible. As a result, high-pressure balloons are used in a variety of diagnostic and therapeutic procedures. Applications include:

- PTCA and PTA catheters
- Other dilation catheters
- Stent delivery catheters
- Heat transfer catheters
- Photodynamic therapy (PDT)
- Laser balloon catheters
- Cryogenic catheters
- Drug delivery devices
- Positioning catheters
- Arthroscopy catheters

*NOTE: Many of the applications/procedures discussed in this paper are experimental and have not yet been approved by the U.S. F.D.A.*

## **TWO BASIC TYPES OF MEDICAL BALLOONS**

Two basic types of balloons are used in the medical industry. One is the high-pressure, non-elastic, dilatation or angioplasty-type balloon used to apply force. The other is the low-pressure, elastomeric balloon typically made of latex or silicone that is used primarily in fixation and occlusion. The two have few similarities. High-pressure balloons are molded to their inflated geometry from non-compliant or low-compliant materials that retain their designed size and shape even under high pressure. They are thin-walled and exhibit high tensile strength with relatively low elongation. Low-pressure balloons are typically dip-molded in a tubular shape which is then expanded several times its original size in use, thus these balloons cannot be inflated to precise dimensions or retain well defined shapes and high pressures.

For angioplasty, balloons must have a controlled or repeatable size (diameter vs. pressure) in order to ensure that the balloon will not continue to expand and damage or rupture the artery after it opens the blockage. Balloon compliance is the term used to describe the degree to which a high-pressure balloon's diameter changes as a function of pressure. A low-compliance, high-pressure balloon might expand only 5 – 10% when inflated to the rated pressure while a high-compliance, high-pressure balloon might stretch 18 – 30%. Conversely, low-pressure elastomeric balloons, which are inflated by volume, not pressure, can stretch 100 – 600%. When the pressure is released, elastomeric balloons recover close to their original size and shape. They usually cannot be used to exert high pressure in medical applications.

## **HIGH-PRESSURE BALLOON MATERIALS**

The first angioplasty balloons were fabricated from flexible polyvinyl chloride (PVC). They were relatively thick-walled and low-pressure compared to today's high-pressure balloons. Crosslinked polyethylene came into use in the early- to mid-80s, about the same time that polyester (PET) polyethylene terephthalate was adopted for high-pressure balloons. Those two materials replaced PVC to a large degree. Nylon balloons came out in the late '80s, and polyurethane balloons followed in the early '90s. Nylon, while not as strong as PET or as compliant as PE, was seen as a compromise because it was softer than PET, but relatively thin and relatively strong. Today most high-pressure medical balloons are made from either PET or nylon. PET offers advantages in tensile strength, and maximum pressure rating while nylon is softer. See Table 1 for a comparison of various high-pressure balloon materials.

**Table 1:** Comparison of High-Pressure Balloons Made with Various Materials

Materials	Tensile Strength	Compliance	Stiffness	Profile	Max. Rated Pressure for PTCA*		Sterilization Methods
					ATM	PSI	
PET	High-Very High	Low-Medium	High	Low	20	294	EtO or Radiation
Nylons	Medium-High	Medium	Medium	Low-Medium	16	235	EtO
PE (crosslinked) and other polyolefins	Low	High	Low	High	10	147	EtO or Radiation
Polyurethanes	Low-Medium	Medium-High	Low-Medium	Medium-High	10	147	EtO
PVC (flexible)	Low	High	Low	High	6-8	88-117	Radiation

\* The maximum rated pressure is based on practical limitations and usefulness. Obviously, very thick walls can be used with any material to increase the rated pressure; however, the balloon would be useless.

Rated pressures for angioplasty balloons are typically in the range of 2 – 20 atmospheres (30 to nearly 300 psi) depending on the size; the larger the diameter, the lower the rated pressure. This is due to the fact that as the diameter of a balloon increases, the stress in the balloon wall increases when inflated to its nominal diameter. Refer to the “**Balloon Mechanics**” section. One major advantage of PET is its unusual ability to be molded into ultra thin walls and very precise shapes. Since PET is ultra-thin-walled, ranging from 5 to 50 microns (0.0002" to 0.002"), it is capable of producing balloons of extremely low profile.

High-pressure PET balloons can be produced with diameters from 0.5 mm to 50 mm or more, in any working length, while maintaining very thin walls. They can be custom designed with varying diameters along the length of the balloon and tapered ends from 1 to 90 degrees. Other benefits include excellent heat transfer characteristics and optical clarity, making PET balloons suitable for use with Nd:YAG and other lasers, ultrasound and microwave energy.

Nylon high-pressure balloons are softer than PET balloons, although not as strong, thus requiring a thicker wall for a given burst pressure. This generally means that nylon balloons will have a larger profile than PET upon insertion into the body and crossing a lesion, but because the material is softer, it is more easily refolded, thus making it easier to withdraw into the guiding catheter or introducer sheath.

## BALLOON BASICS

Virtually all high-pressure balloons are fabricated by first extruding a tube or preform, cross-linking the extrusion if required, then reheating and stretch blow molding the extrusion into the desired geometry. A standard dilatation balloon consists of a cylindrical body, two conical tapers, and two necks (proximal and distal).

**Figure 1.** Standard Balloon

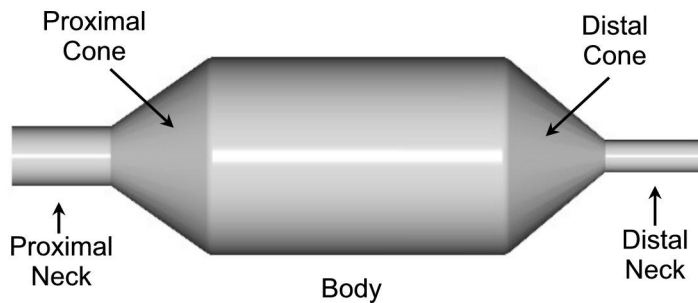

*A standard balloon consists of a cylindrical body, two conical tapers, and two necks (proximal and distal).*



## KEY DEFINITIONS

<b>Balloon Diameter:</b>	nominal inflated balloon diameter measured at a specified pressure
<b>Balloon Length:</b>	typically refers to the working length or the length of the straight body section
<b>Burst Pressure:</b>	average pressure required to rupture a balloon; usually measured at body temperature
<b>Rated Burst Pressure:</b>	maximum statistically guaranteed pressure to which a balloon can be inflated without failing. For PTCA and PTA catheters, this is normally 95% confidence/99.9% guarantee
<b>Balloon Profile:</b>	maximum diameter of the balloon when mounted on a catheter in its deflated and wrapped condition or the smallest hole through which the deflated wrapped balloon catheter can pass
<b>Balloon Compliance:</b>	change in balloon diameter as a function of inflation pressure

## HIGH-PRESSURE BALLOON ENDS

Balloon ends are available in a variety of shapes: conical sharp corner, conical radius corner, square end, spherical end, and offset neck depending on the requirements of the procedure. Other complex shapes are also possible.

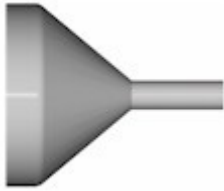
**Table 2.** Typical Balloon Ends

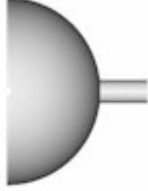
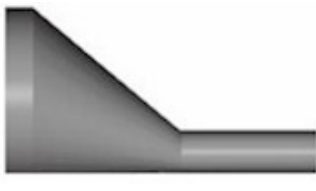
<b>Conical Sharp Corner</b>

<b>Conical Radius Corner</b>

<b>Square End</b>

<b>Spherical End</b>

<b>Offset Neck</b>

## BALLOON MECHANICS

A standard balloon is a thin-walled cylindrical pressure vessel. The stresses in a standard balloon are represented by the following equations:<sup>1</sup>

$$\sigma_r = pd/2t \quad \sigma_l = pd/4t$$

Where:

p = pressure

d = diameter, t = thickness

$\sigma_r$  = hoop or radial stress

$\sigma_l$  = axial or longitudinal stress

From the above equation, the radial tensile strength of a balloon can be easily calculated as follows:

TS = calculated radial tensile strength

$$TS = pd/2t$$

Where:

p = burst pressure

d = diameter (as made)









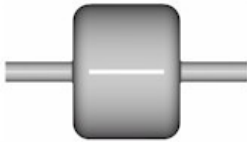
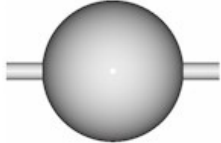

t = thickness (as made)

Fortunately, the radial stress or hoop stress is twice the longitudinal stress; therefore, when a balloon fails, it normally splits along its length rather than circumferentially. Clinically speaking, that is desirable, since radial or circumferential balloon failures can cause complications in many medical procedures.

## HIGH-PRESSURE BALLOON SHAPES

The balloon body can vary from the standard balloon (as shown in Figure 1) as well. It can be sectioned into different diameters and lengths (e.g. dog bone-shaped and stepped balloons) and shaped into conical, square, spherical or a combination of these forms. Different ends can also be used on the same balloon if needed.

**Table 3.** High-Pressure Balloon Shapes

<p style="text-align: center;"><b>Conical Balloon</b></p> 	<p style="text-align: center;"><b>Square Balloon</b></p> 
<p style="text-align: center;"><b>Spherical Balloon</b></p> 	<p style="text-align: center;"><b>Conical/Square Balloon</b></p> 
<p style="text-align: center;"><b>Conical/Square Long Balloon</b></p> 	<p style="text-align: center;"><b>Conical/Spherical Balloon</b></p> 
<p style="text-align: center;"><b>Long Spherical Balloon</b></p> 	<p style="text-align: center;"><b>Tapered Balloon</b></p> 
<p style="text-align: center;"><b>Dog Bone Balloon</b></p> 	<p style="text-align: center;"><b>Stepped Balloon</b></p> 
<p style="text-align: center;"><b>Offset Balloon</b></p> 	<p style="text-align: center;"><b>Conical/Offset Balloon</b></p> 

## APPLICATIONS OF HIGH-PRESSURE BALLOONS

### DILATATION

Angioplasty is the most widely used application of high-pressure balloons today. Dilatation balloons are employed to dilate and unblock arteries that feed the heart in percutaneous transluminal coronary angioplasty (PTCA). Typical sizes of balloons for PTCA catheters range in size from 2 to 4 mm in diameter, 10 to 40 mm long, and are rated for a pressure capability of 10-20 ATM. For (non-coronary) percutaneous transluminal angioplasty (PTA), balloon sizes typically range from 4 to 12 mm in diameter and 20 to 100 mm in length. Rated pressures for PTA 8-20 ATM. PTA procedures include dilation of arteries other than the coronary arteries.



**PHOTO 1.** Angioplasty balloons may be formed in various sizes ranging from small coronary size balloons to large diameter balloons used in peripheral arteries.

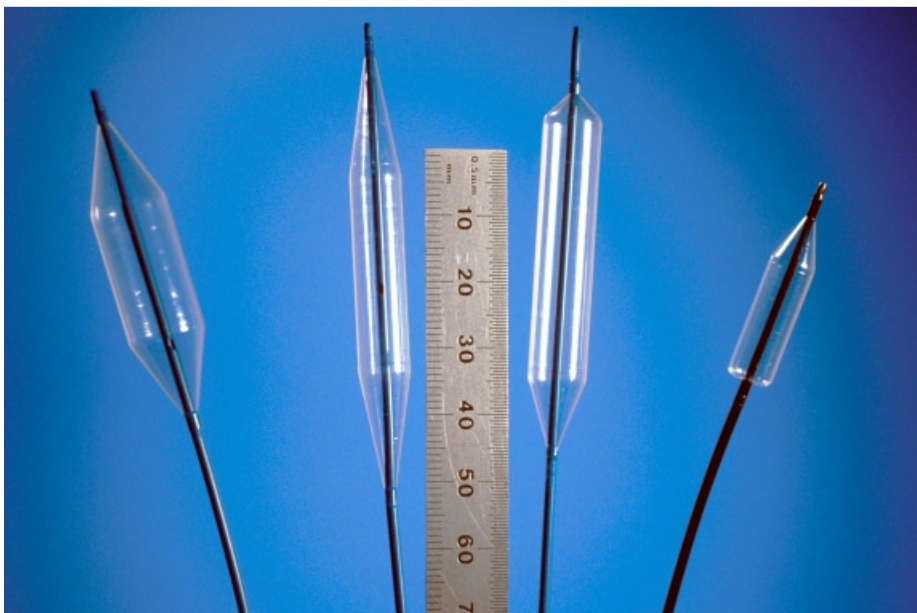
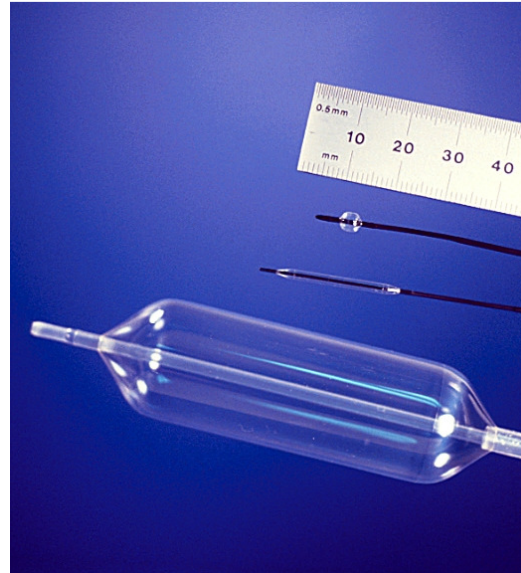

**PHOTO 2.** Balloons may also be formed with different cone angles to meet various balloon taper requirements.

High-pressure balloons are also used and being developed to dilate restrictions and blockages virtually anywhere in the body. These uses include:

- Esophageal dilatation
- Biliary dilatation
- Urethral dilatation
- Fallopian tube dilatation
- Heart valve dilatation (valvuloplasty)
- Tear duct dilatation
- Carpal tunnel dilatation

Many of these markets are new and emerging such as carpal tunnel dilatation while others such as valvuloplasty have been around for many years. All of these applications benefit from high pressure, low compliance, low profile balloons.



**PHOTO 3.** Balloons are formed in a variety of sizes using high performance materials. Pictured here are balloon sizes ranging from 2 to 25mm in diameter. A small round balloon may be used fallopian tube plasty while a large balloon may be used in valvuloplasty.

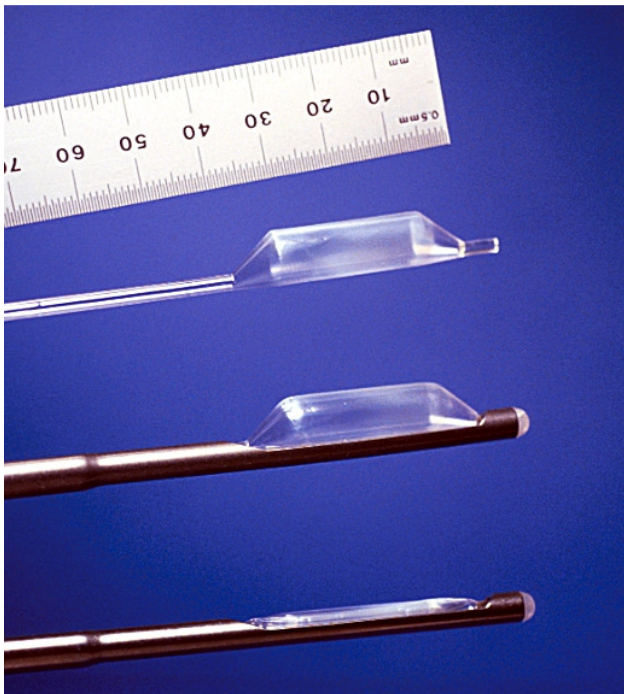

**PHOTO 4.** The balloons pictured here are used in carpal tunnel dilatation.

The top balloon is shown as formed.

The middle balloon is shown in its assembled state and inflated.

The bottom assembly illustrates the deflated profile of the same balloon.

*Carpal Tunnel Dilatation Assembly courtesy of United States Surgical Corp.*



## STENT DELIVERY

High-pressure balloons are commonly used to deploy and post dilate stents to reduce the rate of arterial restenosis and acute reclosure following angioplasty. Stents are metallic scaffolds implanted to support the walls of arteries and other body cavities. Coronary stents, machined metal tubes or wire mesh, are crimped over a balloon and inserted into the area of a blockage after angioplasty. Inflating the balloon opens the stent, which remains expanded to keep the vessel open. The use of high-pressure balloons allows the physician to fully expand the stent until it is in full contact with the arterial wall. The use of a low compliance balloon allows the added confidence that the stent and the artery will not be over-expanded as well as the balloon will not dog-bone and over-expand the artery on either end of the stent. The stent stays in position after the balloon is deflated and removed from the body. Stents are being used with increasing frequency in association with angioplasty procedures. This is the second largest market for high-pressure balloons today.



**PHOTO 5.** This photograph illustrates an arterial stent in its expanded state. The wire mesh creates a scaffold to maintain a fluid pathway to maximize the blood flow past an arterial blockage.

*Photo courtesy of IntraTherapeutics*



*Photo courtesy of IntraTherapeutics*

**PHOTO 6.** This photograph shows the stent as it is ready to be inserted into an artery. The stent is at its minimum diameter and crimped over a balloon. The balloon will be inflated once the physician positions the device in the desired section of the artery. The expanded stent will then remain in place permanently.



*Photo courtesy of IntraTherapeutics*

**PHOTO 7.** This photograph shows the stent expanded by the balloon. The balloon is used to press the stent scaffold against and partially into the arterial wall. This insures the artery will be fully patent and provide the optimum blood flow.

## POSITIONING

High-pressure balloons can be used to precisely position a device in a vessel or body cavity. This is a new market for specialty technologies. Elastomeric balloons are often used for positioning; however, high-pressure balloons are preferred when a precise shape or position is required. An elastomeric balloon can stretch and roll shifting back and forth which is unacceptable in critical positioning applications. In addition, elastomeric balloons often inflate non-concentrically and unpredictably which preclude their use in precision applications.

A balloon can be used to center a device such as radioactive seeds in a vessel to deliver radiation in hopes of preventing restenosis. Centering the device ensures symmetrical dosage around the wall. Some procedures concentrate on only one side of a vessel or cavity, such as directional arthrectomy, which cuts away plaque from vessel walls. The procedure uses a cutter that spins at high speed inside a housing. A balloon is mounted to the back of the housing and inflated, pushing the cutter against the wall of a vessel, allowing it to be debulked.



**PHOTO 8.** On the left is a high pressure, thin walled balloon. On the right is an elastic latex balloon. Elastomeric balloons often unintentionally expand asymmetrically as seen here.

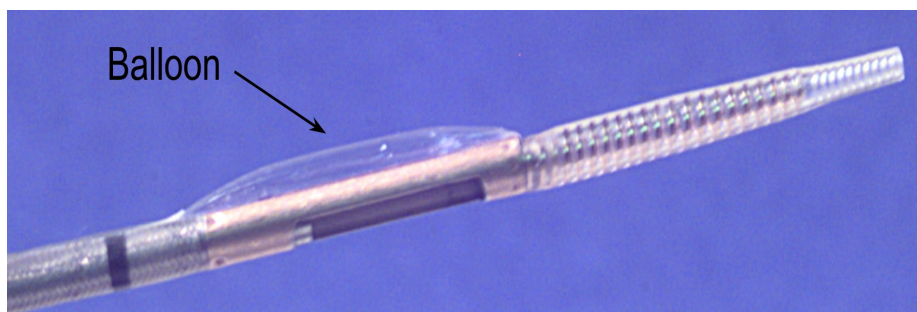

*Source: Guidant Corp.*

**PHOTO 9.** A directional coronary arthrectomy catheter is shown with the balloon inflated. The balloon is mounted on the back of the cutter housing and it is used to push the cutter against plaque.

Another example is the treatment of BPH (benign prostate hyperplasia) or enlarged prostate gland. In this application, an off-set balloon can be used to position a device off to the side, directly against a lobe of the gland, to deliver microwave or laser energy only where it is needed or conversely a standard balloon can be used to insure that the device remains centered.

High-pressure balloons are also used to position diagnostic devices in ultrasound imaging and other techniques that require locating them inside vessels or body cavities. Rather than having a complicated steering or positioning mechanism on the end of a catheter, a high-pressure balloon can be used to either center or offset the device, precisely positioning it as required.

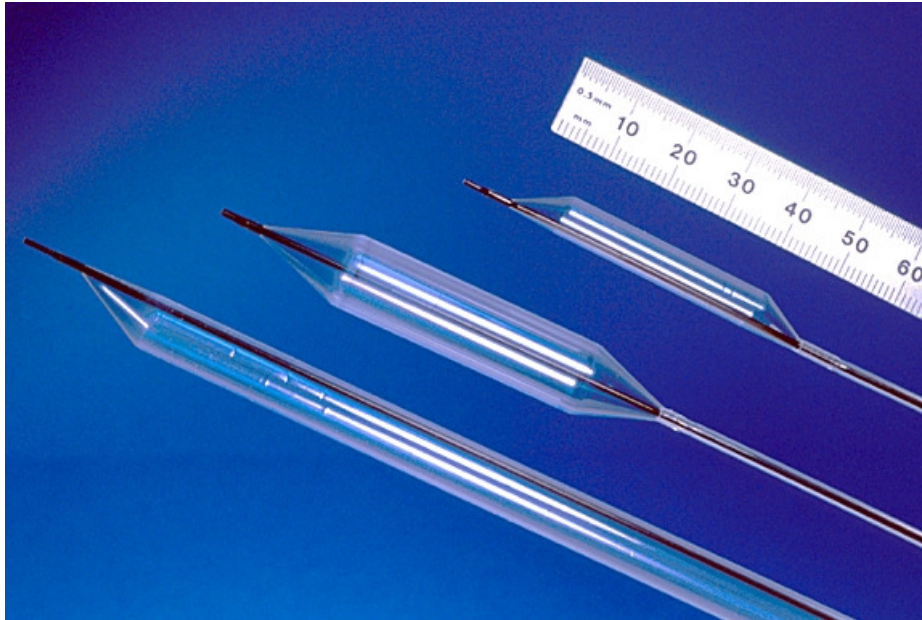

**PHOTO 10.**

High-pressure balloons designed to be offset (top and bottom balloons) and centered (middle balloon). Offset balloons can be used to position various instruments to concentrate on one wall while symmetrical balloons precisely center an instrument in a body cavity.

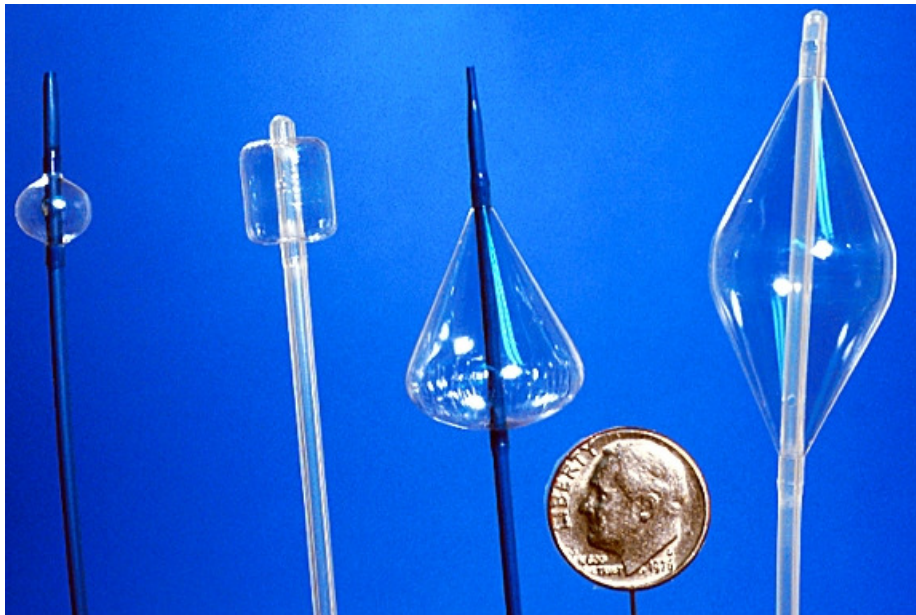

**PHOTO 11.**

A balloon with a narrowing in the body can be used to position a device laterally within a structure such as a valve. The larger diameter on either end ensures that the device will not move proximal or distal to any great degree.

## OCCLUSION

Normally, low-pressure, elastomeric balloons are used for occlusion or sealing, but in some cases, when precise sizes or shapes are required, it is desirable to use a high-pressure balloon. Also, high-pressure occlusion balloons can be made shorter or longer than elastomeric balloons and can reduce or increase the surface area covered in the vessel or cavity. Because high-pressure balloons can be precisely shaped, particularly in the transition area, they offer advantages over elastomeric balloons whose ends are always spherically shaped. Conical, square or spherical shaped high-pressure balloons are typically used for various occlusion applications.



**PHOTO 12.**

A variety of complex shapes can be fabricated from PET. Shapes can be formed to completely fill various shaped body cavities.

## ENDOVASCULAR GRAFT DELIVERY

This is a new market in which high-pressure balloons are being used to repair aneurysms as an alternative to open surgery. A balloon-mounted, woven artificial graft with a stent-like structure built in on each end or over the entire length is wrapped tightly onto the balloon to minimize its profile. The graft, which is longer than the aneurysm, is deployed and attached to the artery wall by inflating the balloon within the artery. The graft by-passes the weakened area of the artery and it remains in place permanently anchored to the vessel wall. The graft then restores normal circulatory flow after the balloon is deflated and removed.<sup>2</sup> A wide variety of diameters and lengths are required in this procedure. Tapered and custom-shaped balloons are sometimes needed, as well.

## MULTIFUNCTIONAL BALLOONS

High-pressure balloons can be designed to perform several tasks at once. For procedures that require the balloon to perform multiple functions, such as occlusion as well as device positioning, a high-pressure balloon performs very well. Many of the examples discussed throughout this paper are examples of multifunctional balloons.

A treatment for benign prostate hyperplasia (BPH) involves the application of thermal energy to the prostate with a microwave antenna inside a balloon. Microwave energy is emitted through the walls of the balloon, heating the prostate from the inside out as the microwaves penetrate the tissue. The antenna must be cooled during the procedure to keep it from overheating. That is achieved with a cooling fluid that also cools the lining of the urethra protecting it from thermal damage. As an added function, a small side lumen is added to the cooling balloon that positions a thermal sensor precisely relative to the curve of the catheter and holds it against the tissue being treated. The sensor can be used to control the energy level of the microwave antenna and cut off power if the temperature gets too high.

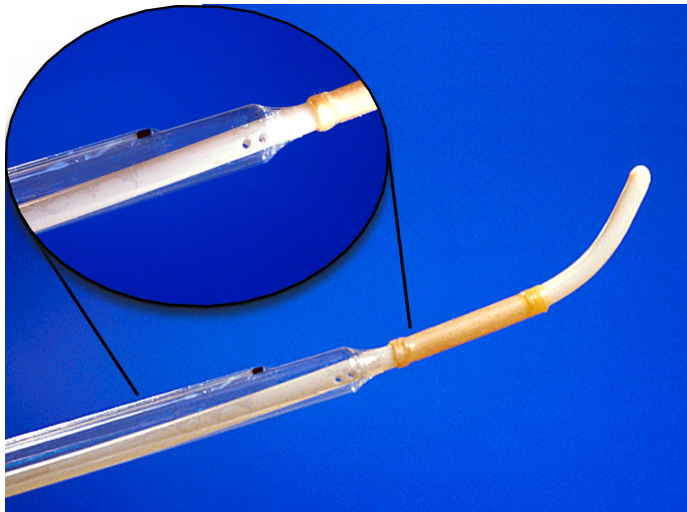
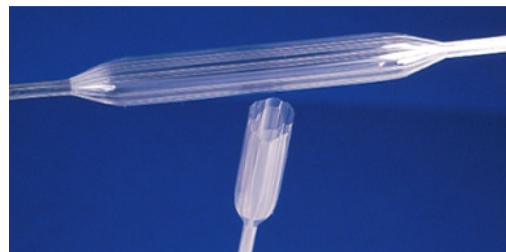

**PHOTO 13.**

This photograph shows the cooling balloon and the sensor side lumen used in the treatment of BPH. The small black dot shown close-up is a temperature sensor.

## MULTILUMEN BALLOONS

Balloons can be created with multiple lumens or channels so as to allow the balloon to perform multiple functions in both the inflated and deflated state.<sup>3</sup> For example, a multiple lumen balloon can be fabricated so as to allow blood to profuse (flow) through one or multiple lumens while the other lumens inflate to perform angioplasty. In another design, one or more of the lumens could be used to contain a diagnostic or therapeutic device or multiple devices for precise positioning.



**PHOTO 14.** A multilumen balloon can be used to perform many functions with a single device. Note the various lumens and their shapes in the cross-section shown below the balloon.

## LIGHT THERAPY

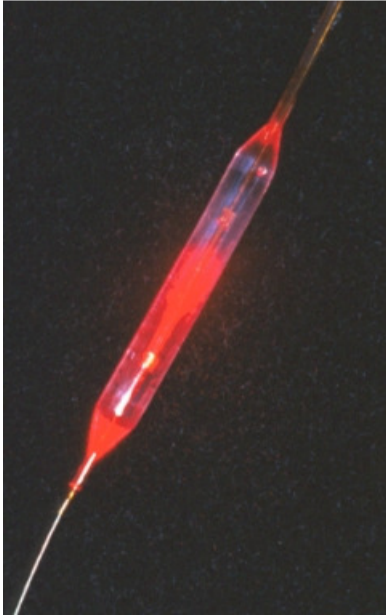

*Photo courtesy of Dr. Richard Spears, M.D.*

**PHOTO 15.** A laser balloon angioplasty (LBA) device used in coronary angioplasty.

emitted through the clear “window” portion of the balloon and the drug is activated which in turn destroys the bad cells. The inflated PDT balloon opens the esophagus, which is normally collapsed, and centers the laser delivery device. The opaque coating on the ends of the balloon prevents the light from treating other healthy areas of the organ so that only the cells exposed to the light are destroyed.

PET balloons are optically clear and permit the transmission of light over a broad spectrum, making them well suited for Laser Balloon Angioplasty (LBA) and Photo Dynamic Therapy (PDT) with light-activated drugs. The simultaneous application of heat and pressure during laser balloon angioplasty of coronary arteries reduces arterial recoil, remodels thrombus into a non-obstructive film, eliminates vasospasm, and may seal dissections induced during initial conventional PTCA.<sup>4</sup> Devices mounted inside the balloon can emit light through the wall of the balloon.

PDT is currently being used in the treatment of Barrett’s esophagus. Barrett’s esophagus is a pre-cancer condition that is being experimentally treated by a light activated drug. In this treatment, the patient is given an intravenous drug treatment 1 to 2 days before light therapy. A laser delivery device is mounted inside a specially designed balloon catheter and introduced into the patient’s esophagus. The balloon is inflated in the treatment area and the laser is activated. The laser light is

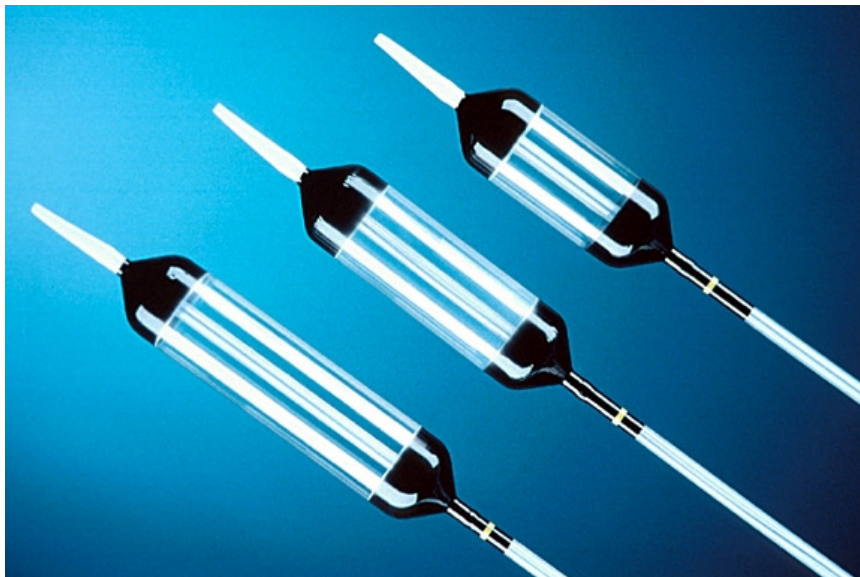

**PHOTO 16.**

The balloon catheters pictured are used to deliver laser light energy to the esophagus for the treatment of Barrett's esophagus. The various "window lengths" provide optical treatment areas.

*Photo courtesy of  
Wilson-Cook Medical, Inc.*

## DRUG DELIVERY

High-pressure balloons are very useful in several different applications used for drug delivery. These techniques localize the medication and are an effective alternative to administering it intravenously, which delivers the drug systemically to unwanted areas throughout the whole body. One method that can be used to deliver a toxic drug to a blockage or lesion is to use two discrete balloons mounted on a catheter shaft to seal off the afflicted area, while the medication is infused through a port in the catheter between the two balloons. Once the treatment is complete, the fluid is drained, the area is flushed, and the balloons are deflated and retracted. A dog bone-shaped balloon (See Photo 11) can also be used to deliver drugs in a similar manner. The ends of the balloon can be of equal or different sizes, depending on the shape of the cavity or vessel. When inflated, the ends seal off the area to be treated, and the medication is infused through a hole or series of holes in the narrower center section of the balloon. The holes can be made in the surface of the balloon with a laser, hot wire, or drilling device creating a sort of sponge. This can also be done to virtually any balloon.

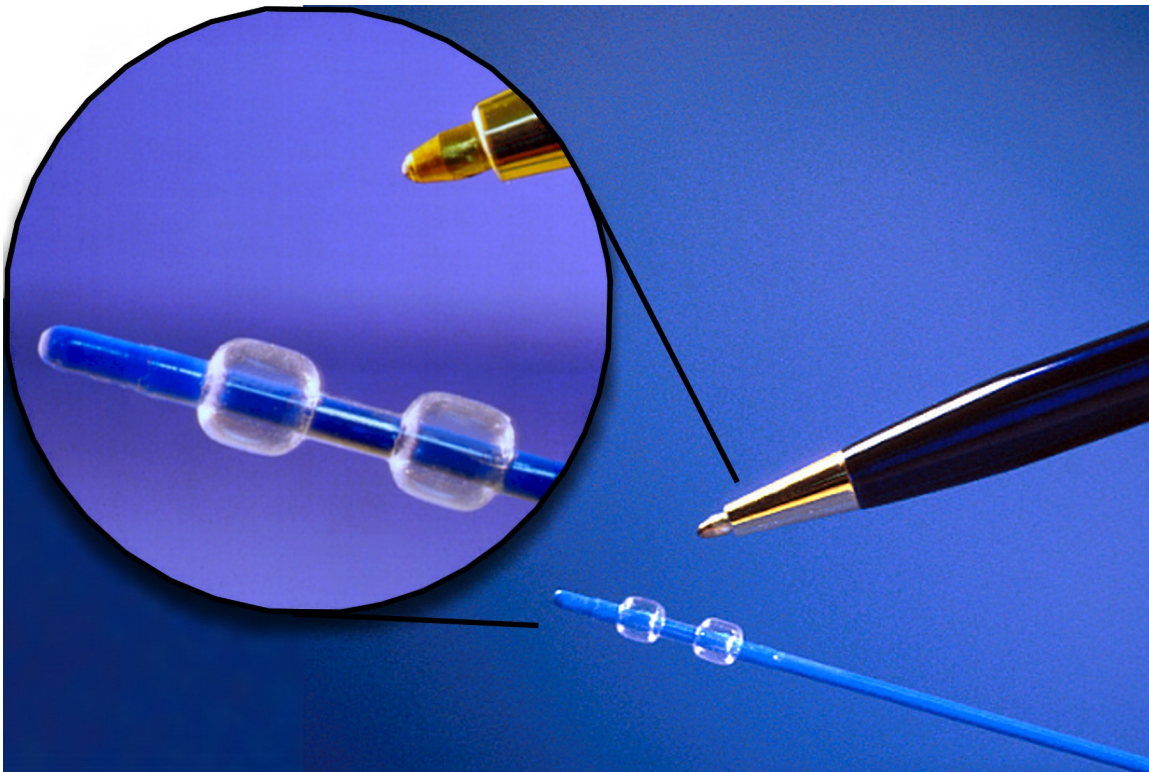

**PHOTO 17.**

Two discrete balloons or a "dog bone" shaped balloon can be used to seal off an area to be treated without subjecting too large an area to the medication. This also limits the amount of some times very toxic and/or expensive medication needed.

Alternatively, an ultra-thin-walled PET balloon can be converted to a micro porous membrane with hole sizes ranging from submicron to a few microns in diameter. Hundreds of thousands or even millions of holes can be placed in a single balloon. This provides an even better method of drug delivery because the pore size can be controlled precisely, enabling very small amounts of a drug to be infused over a well-defined area as large or as small as required. This is critical with drugs that are both expensive and toxic. Although these balloons contain millions of micro pores they are surprisingly very strong due to the material's unique structure.

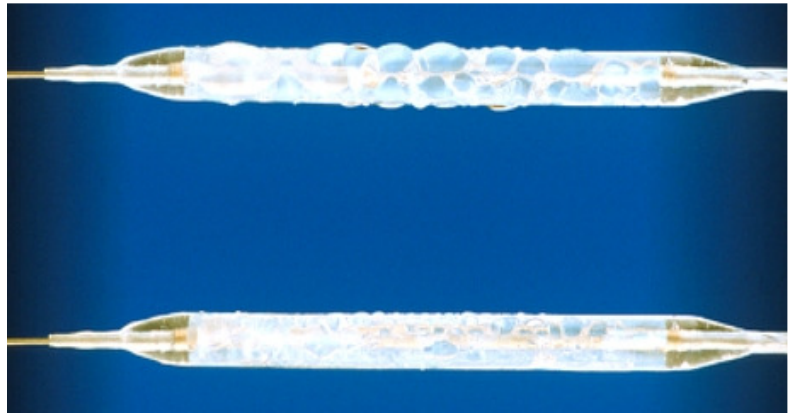

*Photo courtesy of ē-Med*

**PHOTO 18.**

This photograph shows the balloon membrane "weeping" medication. When in use, the medication spreads in a thin film between the balloon membrane and the tissue forcing the medication into and around the cell walls.

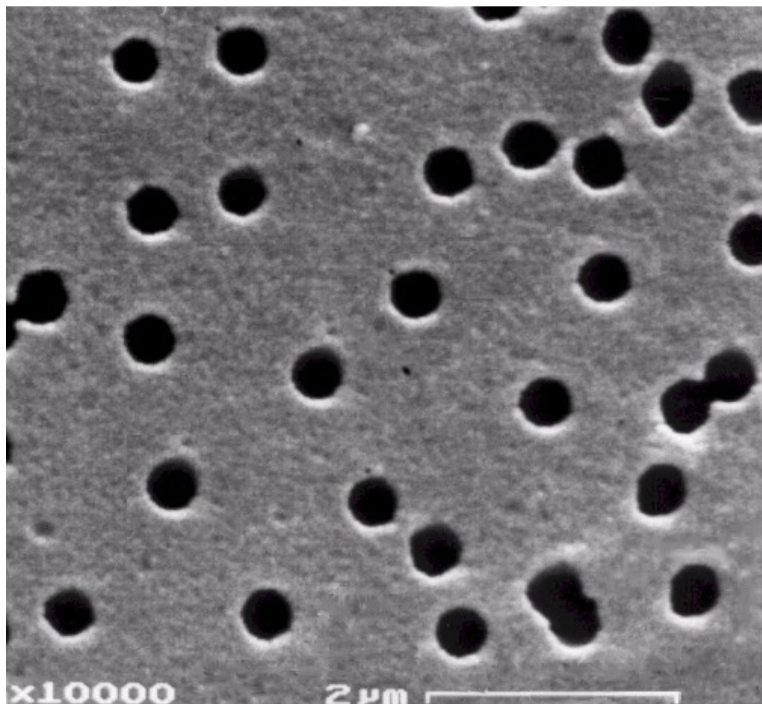

*Photo courtesy of ē-Med*

**PHOTO 19.**

The SEM (Scanning Electron Photomicrograph) shows the number, scale, and uniformity of the micro pores formed in a balloon membrane. There can be hundreds of thousands or millions of these in a single balloon membrane. The holes shown here are about 0.5 microns in diameter.



In fact, the balloons can still be used for angioplasty. While the inflated balloon dilates the afflicted area, it can also infuse medication, perhaps delivering an anticoagulant onto the vessel's wall. Drug absorption and penetration into the vessel wall can be controlled by the rate of fluid flow across the membrane and the pressure the fluid is delivered at. By controlling the hole size and pattern, the fluid flow can be governed and directed.

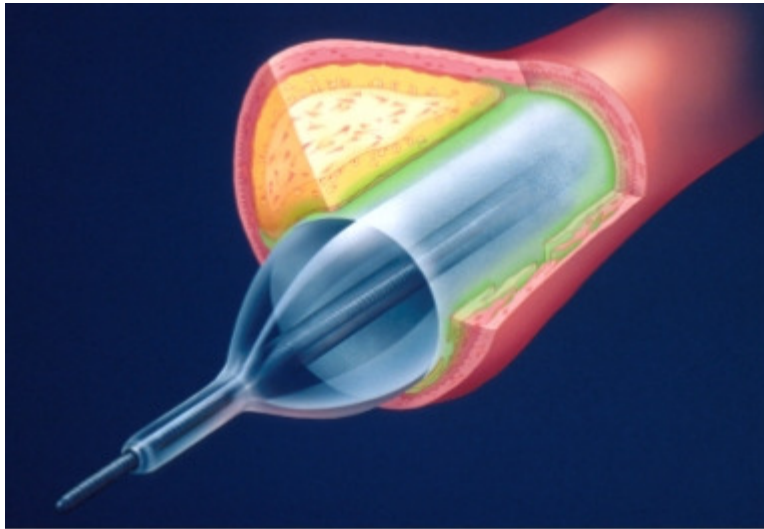

*Photo courtesy of e-Med*

**PHOTO 20.**

This illustration shows a multifunctional microporous balloon being used for both angioplasty and drug delivery.

Drugs can also be coated onto the surface of a balloon and delivered to a specific site in the body. Transfer of the drug from a balloon's surface to the cavity wall can be accomplished with pressure, heat, laser light, etc. Experimentally, laser & thermal energy has been used to enhance the binding of heparin to an injured arterial wall. In the experiment, lesions were treated immediately after PTCA, with a laser balloon that had been coated with heparin. The results suggest that heparin therapy is a safe treatment that yields favorable acute angiographic results.<sup>5</sup>

## HEAT-TRANSFER CATHETERS

High-pressure balloons can be used to transfer heat or cold, either into or out of a vessel or cavity and can be readily inflated and deflated so as to provide easy low profile entry and exit while providing large diameters and surface area when inflated in use. They serve as a very good medium because their ultra thin walls provide a relatively high rate of heat transfer. The balloons also provide intimate contact with the area being treated, conforming to curves and irregularities in the surface of a vessel. For example, in cryosurgery of the prostate, a specially designed fluid circulating high-pressure balloon catheter is inserted in the urethra.<sup>6</sup> The long thin-walled balloon covers the entire length of the urethra up into the bladder to protect the urethra and sphinctor muscles from being damaged by the extreme cold produced by cryoprobes inserted in the prostate gland. Flexibility, conformability and high heat transfer rates are critical to protect tissue and muscles in the application.

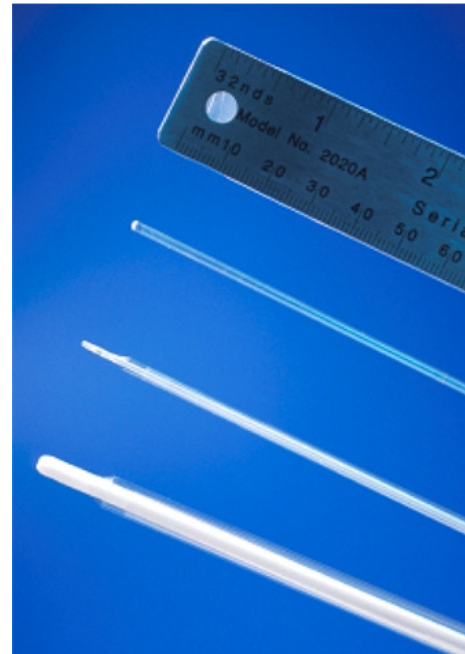

**PHOTO 21.**

Heat transfer catheters are made in various sizes to accommodate different devices and anatomy.

## BALLOON COATING

A wide variety of coatings can be added to the surface of a balloon to enhance or change its properties to meet new requirements. Balloon coatings include the following:

- Lubricious coatings (hydrophylic and hydrophobic)
- Abrasion and puncture resistant coatings
- Tacky or high friction coatings
- Conductive coatings
- Anti-thrombogenic coatings
- Drug release coatings
- Reflective coatings
- Selective coatings

## CONCLUSION

High-pressure balloons, traditionally used only in angioplasty, are now used in a wide range of diagnostic and therapeutic devices due to improvements in materials, balloon design and fabrication technology. These improvements include increased diameters, additional lengths, ultra-thin walls (for minimal invasion and a smaller profile), varying diameters throughout the balloon, custom shapes, tapered ends and angles, and specialty coatings, among others. High-pressure balloon technology has led to the unique capability of designing and manufacturing multifunctional balloons that provide endless product design possibilities for the medical device design engineer. A single balloon or device can now have many functions. All of these enhancements are enabling designers to develop new and improved medical devices.

For more information contact:

Advanced Polymers, Inc.  
29 Northwestern Drive  
Salem, NH 03079 USA.  
Tel. (603) 327-0600  
Fax: (603) 327-0601  
E-mail: [info@advpoly.com](mailto:info@advpoly.com)  
Web site: [www.advpoly.com](http://www.advpoly.com)

---

<sup>1</sup> Beer and Johnston, ed., "Mechanics of Materials", McGraw-Hill, Inc., 1981, pp. 325-327.

<sup>2</sup> Baxter Healthcare Corporation, PR Newswire, Aug. 11, 1999.

<sup>3</sup> U.S. Patent No. 5,342,301, Saab, "Multi-lumen Balloons and Catheters Made Therewith", Aug. 30, 1994.

<sup>4</sup> James J. Glazier, MD, Alice J. Jiang, MD, Richard J. Crilly, PhD, and Richard Spears, MD., "Laser balloon angioplasty combined with local intracoronary heparin therapy: Immediate and short-term follow-up results", American Heart Journal, 1997;134(2)(1):266-273.

<sup>5</sup> Ibid.

<sup>6</sup> U.S. Patent No. 5,624,392, Saab, "Heat Transfer Catheters and Methods of Making and Using Same", April 29, 1997.